



VOLTAGE OPTIMISATION

Businesses across the UK are suffering from high energy costs, but there is something that can be done to help them use less energy.

By optimising the voltage supply to your electrical equipment you can reduce your energy consumption by up to 19%, therefore saving you money, energy, and carbon.



**Up to 19% reduction
in Electric Spend**



**Typical payback
of under 2 years**



**Lower Carbon
Emissions**

**THE
CHEAPEST
KWH IS
THE ONE
THAT YOU
DON'T USE**

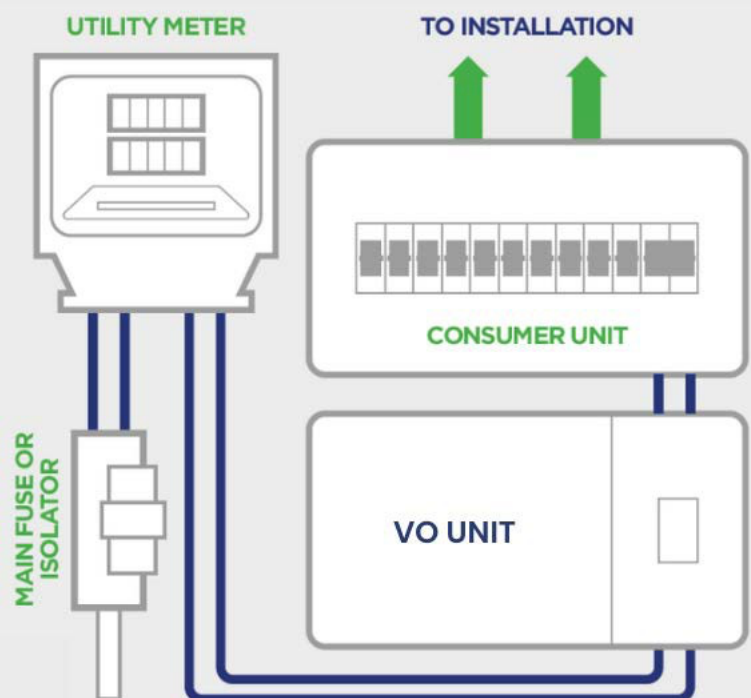

HOW DOES IT WORK?

Voltage optimisation (VO) is a transformer-based technology which optimises the incoming supply from the national grid to match the voltage required by equipment at your organisation.

UK appliances need 220 volts to operate at an optimum level, the average supplied by the National Grid is 242 volts and we have seen as high as 261 volts!

Installing a Voltage Optimiser will give guaranteed savings as well as increase the longevity of your appliances.

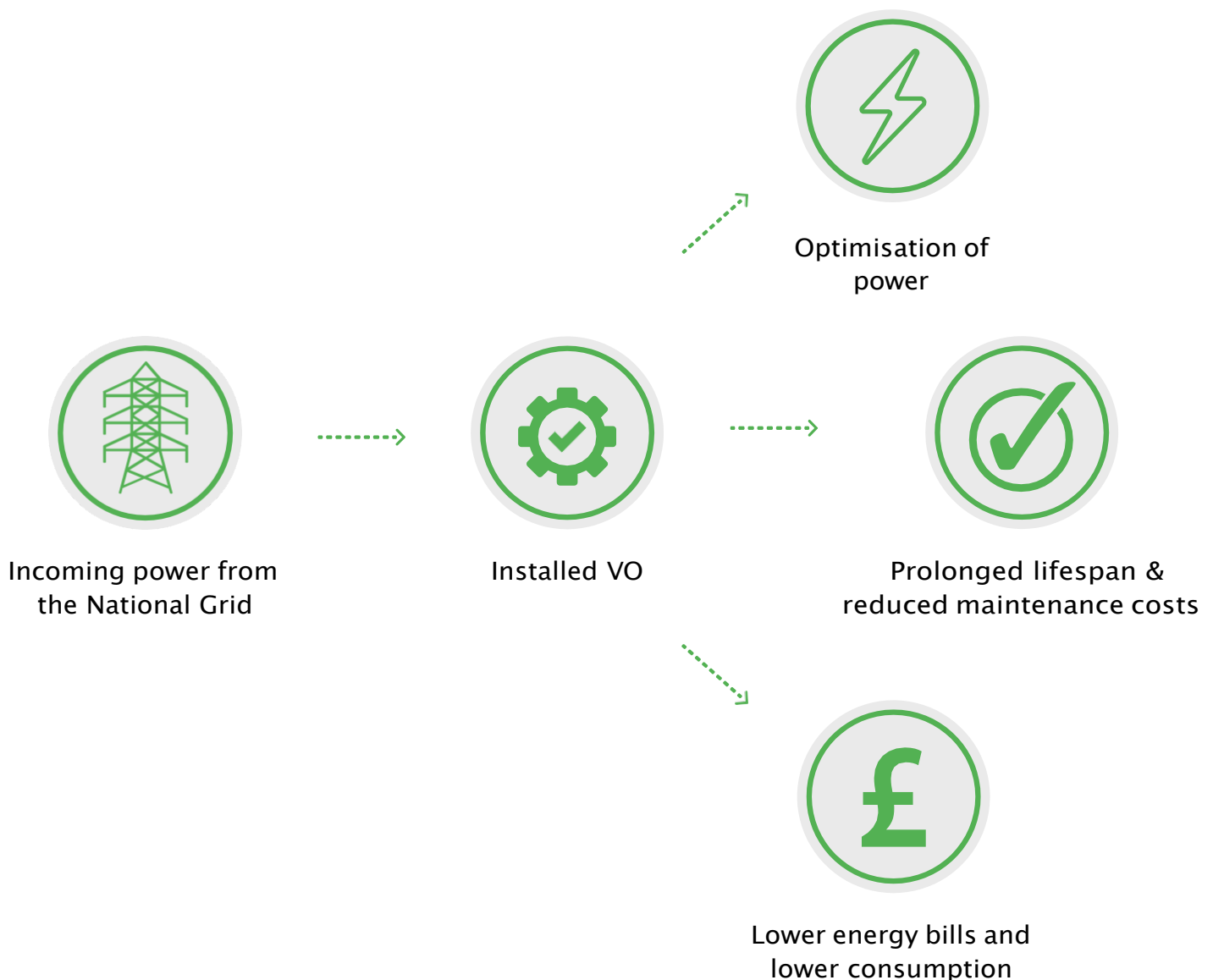

THE PROCESS

1 We will provide an estimated saving based on the average voltage supplied by the National Grid and present the expected ROI.

2 A plug-in voltage tester will be sent to the site, which is simply plugged into any power socket. A photo is taken of the Voltage reading and sent back to us along with pictures of:

- ♦ the fuse board
- ♦ the electricity meter
- ♦ the area around both of these, which is the most likely location for the VO installation

Optimiser sizes can range from a small wall-mounted box to the size of a washing machine.



3 The return on investment will then be confirmed and a final proposal locked in. Voltage Optimisers can be purchased outright, or leased on a finance model enabling the savings to start from the first month.

4 A payment of 50% is required. The kit is then ordered and a delivery and installation date are set.

5 The final balance is due a week before delivery. The kit is then installed, commissioned and signed off by client and the savings begin!

HOTEL EXAMPLE

Example based on a hotel quoted with an annual consumption of just under 3 million kwh with 10 meters and 7 VO units installed.



£100,268

Estimated annual savings



21 MONTHS

Estimated ROI



88,915 KG

Harmful carbon emissions cut

SCHOOL EXAMPLE

Example based on a school quoted with an annual consumption of 678,297 kwh with 3 meters and 11 VO units installed.



£10,565

Estimated annual savings



37 MONTHS

Estimated ROI



12,366 KG

Harmful carbon emissions cut

BENEFITS FOR BUSINESSES

The possible oversupply of power means that you could be paying for more electricity than you need. Excessive voltages also decrease the life of your appliances.

By installing a voltage optimiser, you can reduce the voltage supply to your equipment, securing substantial energy savings and extending the lifespan of your electrical assets.



Immediate savings on electricity bills



Easy installation by qualified technician



Typically a payback of under 2 years



Electrical equipment longevity



Carbon footprint reduction



Works with solar PV and EV charging

IT'S AS SIMPLE AS

ONE

Contact the team and we will run your calculations

TWO

We will recommend the best solution to help reach your savings target

THREE

Install and start saving money, energy and carbon