



TRUST THE ENERGY EXPERTS

Let us help you get the best value from your energy contracts



WHAT WE DO

We are changing the way businesses procure their energy. Energy procurement is extremely complicated and if you get it wrong, it can be very expensive. To remove the stress of dealing with energy contracts and suppliers, we handle all the administration from start to finish, which saves your business time and money.

Not only do we procure energy, but we also provide all the other services you would expect from one of the UK's leading utilities and energy consultants. We help our customers get the best value from their energy contracts, reducing their energy consumption, minimising their carbon footprint and ensuring that their bills are right.

We work on behalf of our clients and thousands of businesses rely on us for their energy needs, whether that be one site or multi-sites across the UK, so let us guide you in this vital decision.

- Constantly monitoring the market to procure energy at the most beneficial period
- Working closely with your business to lower your usage, emissions and bills
- Access to the best market pricing available from carefully selected suppliers



Energy Procurement



DPS Framework



Consultancy



Solar PV Panels



EV Charging



Automatic Switching Service

WHAT MAKES US DIFFERENT?

Time is precious for all businesses, so we remove the stress of dealing with energy contracts. We analyse the market for the best deal and negotiate with suppliers, managing the process from start to finish to allow you to spend more time on your business.



Tailored
Solutions



Time
Efficient



Trustworthy
Name



Constant Point
of Contact



Impartial
Advice



Indepth
Analysis



Innovative
Software



Money
Savers



No Cold
Calling



No
Pestering

GREEN SOLUTIONS FOR BUSINESSES

Be part of the *solution*, not part of the *problem*.

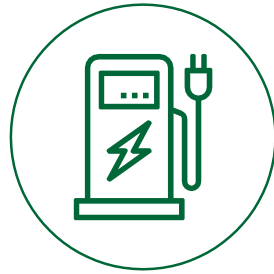

Electric vehicle charge points, installed at your workplace



100% Renewable Energy from a range of green suppliers



Tailored solutions and products to minimise your carbon footprint

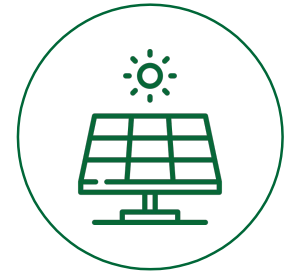

Solar PV panels installed for self generation



RENEWABLE ENERGY TARIFFS

With many suppliers now offering 100% renewable energy, prices are becoming more competitive and going green might even save you money along with helping the planet.

Powering your business doesn't need to have a detrimental effect on the environment. Attitudes and behaviours are changing and many businesses are opting to go for a greener alternative when it comes to their business energy.

All our green products use power generated from 100% renewable sources. They come with a zero emissions rating and are backed with a "Guarantee of Origin", certifying that the electricity has been generated exclusively through wind (hydro assets).

Renewable energy products are available to all our customers who care about the environment and wish to make an impact, no matter how big or small your company may be.



EVCHARGING

Almost 9 million electric vehicles (EV's) are expected on the road by 2030. They can enhance your brand reputation, help with the reduction of emissions and create another customer base, by attracting new customers to visit your business.

We offer EV charging solutions, that can be customised with your company branding and installed at your workplace for the use of your employees and company vehicles. We also provide the specialists to handle every aspect of the process, from initial consultation through to installation and maintenance packages.

There is also the opportunity to commercialise your EV charging points, allowing you to rent them out to the public and create an additional revenue stream for your business.

- Workplace Charging Scheme (WCS) government grant of up to £350 per charging point
- Low cost, easy to use and bespoke branding options available across a wide range of charging points
- More sustainable, helping to reduce vehicle emissions of employees and customers



Attract Customers

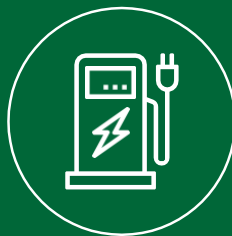

Bespoke Branding



Environmentally Efficient



Government Grants

SOLAR PV PANELS

It is already cheaper to generate energy through solar generation than purchasing conventional electricity from the grid. Early adoption is key to the survival of UK business operation.

Businesses can harness this infinite energy resource to unlock further financial and environmental benefits whilst capitalising on energy savings and meeting sustainability goals.



Mitigate your business risk

Avoid the impact of future carbon legislation for businesses.



Take back control of your energy

By reducing your grid reliance, you become more energy independent.



Reduce your carbon footprint

Cement your position as an environmentally conscious organisation.

Installations usually save businesses around 30% on their current energy costs and there are purchasing options available. Choosing an outright purchase means the only cost implication is the upfront investment. Dependent on cash flow and system size, lease agreements are a powerful tool for businesses.

VOLTAGE OPTIMISATION

Businesses across the UK are suffering from high energy costs, but there is something that can be done to help them use less energy.

By optimising the voltage supply to your electrical equipment you can reduce your energy consumption by up to 19%, therefore saving you money, energy, and carbon.

THE BENEFITS:

- ✔ Immediate savings on electricity bills
- ✔ Typically a payback of under 2 years
- ✔ Electrical equipment longevity
- ✔ Carbon footprint reduction
- ✔ Works with solar PV and EV charging

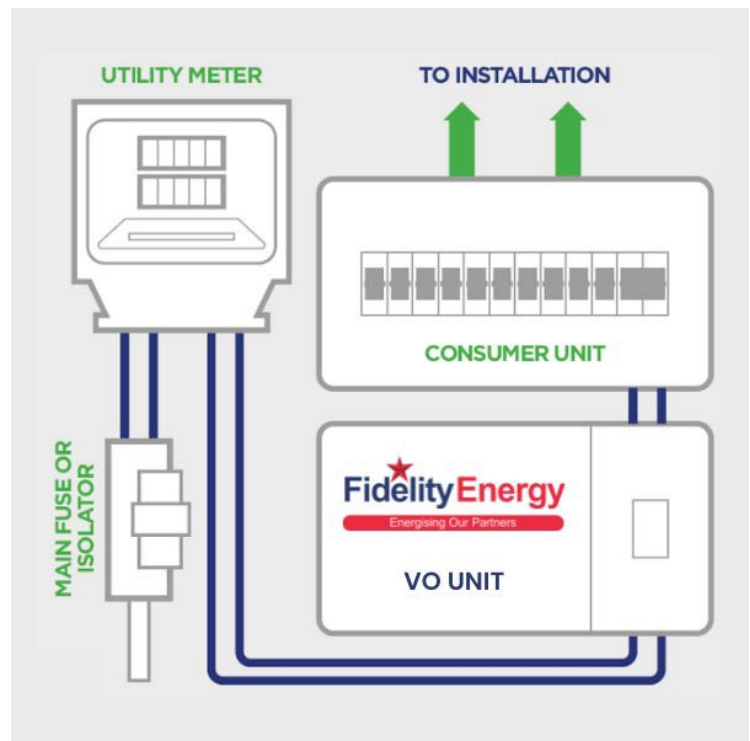

The possible oversupply of power means that you could be paying for more electricity than you need. Excessive voltages also decrease the life of your appliances.

By installing a voltage optimiser, you can reduce the voltage supply to your equipment, securing substantial energy savings and extending the lifespan of your electrical assets.

DPS FRAMEWORK

A DPS (Dynamic Purchasing System) is a tool for contracts to purchase works, goods and services commonly available on the market. Many organisations within the public sector use a Dynamic Purchasing System (DPS) to be compliant but also allow for flexibility to help streamline the procurement process. We can offer all our public sector clients all of our services, but some of the the DPS Framework benefits are:



Compliant and Legal

- > Fully public sector compliant
- > Process Compliant Report to prove all steps have been actioned correctly
- > CCS Approved and OJEU Compliant



Flexible

- > Not a fixed agreement
- > Suppliers can join or be removed at any time
- > Filter requirements to find suppliers who best meet the criteria



Simplified Tender Process

- > Entirely electronic
- > Freely available allowing for full transparency
- > Suppliers requests and return of tenders must be completed within 10 working days

Did you know that 1 in 3 charitable organisations are not on the correct VAT rate for their gas and electricity?

We can check that you are being charged the correct rate and help you claim any clawbacks if you have been overcharged.

SWITCH ONCE SWITCH F∞REVER

You can save both time and money for your business whilst we take away the stress of switching, forever.

We understand that running a business can be stressful. We want to use our expertise to make things easier for our customers, to give them more time to do what they do best. Therefore, we continually look for innovative ways to streamline the switching process.

That is where Switch Once, Switch Forever comes in. If you opt in, every time your contract is up for renewal, we will make sure you are always on a great deal without you having to lift a finger.

THE PROCESS



Step 1 You Sign Up

Sign up to our Switch Once, Switch Forever service and select the contract and supplier preferences you'd like us to follow.



Step 2 We Search

Each time your contract is up for renewal, we compare the market against your chosen preferences to find the best deal suited to you.



Step 3 You Save

We take care of all the contract admin and supplier negotiations, whilst keeping you updated throughout the entire process.



Step 4 We Repeat

The next time your contract is up for renewal, we repeat the process to ensure you're always on a great deal, without having to lift a finger.

WORKING WITH US

Working with us brings the following additional benefits:



Bill Validation

Send us your new bill and we will make sure you're being charged with what was agreed.



Full Customer Account Management

All moves, adds and changes are carried out by us. We'll even cover the opening of new sites and meter installs.



Service Streamlining

We can align all your sites, services and contract end dates, making it simpler to manage your energy movements.



Proactive Contract Management

We'll make sure you never fall into out-of-contract rates again and we'll pick the best time to renew your contracts.



Proactive Termination Notices

We will manage all communications with your current supplier should you choose to move.

WHAT WE NEED FROM YOU

Before we get started on our search for the best deal for your company, we'll need a few things from you:



Copies of some recent
gas and electricity bills
from your current supplier.



A signed letter of authority
(LOA) on your companies
headed paper.

Why do we need an LOA?

The letter of authority allows us to find out from the existing supplier's information like the contract end date, or it is used to obtain the relevant meter data showing how and when you use your energy and gas. Furthermore, it allows us to request bespoke pricing from the suppliers on your behalf. Importantly, we won't do anything with the LOA without your permission!

We can send an LOA to you as a PDF or word document for you to print and fill out before scanning and sending back to us.



Why wait to secure your energy?

Contact us today for a free review!

T: 0208 187 7875

E: customerservice@mpsbusiness.co.uk